



QL2-OCS Water Filter

9275-60

Affordable Premium Quality Office Coffee Water

BENEFITS

- Improves coffee flavor by removing chlorine and other off tastes and odors.
- Reduces dirt larger than 1/2 micron.
- Inhibits costly mineral scale build-up.
- Increases energy efficiency.
- Increases holding time.
- Increases brewer life – reduces corrosion.
- NSF Standards 42 and 53 listed.
- Simplified plumbing and “quick release” head for fast and easy installation and cartridge change.



APPLICATION/SIZING

For low volume plumbed-in coffee brewers with a flow rate of .2 gpm or less.

QL2-OCS System: 9275-60

OCS Replacement Cartridges (1 pack): 9618-01

OCS Replacement Cartridges (12 pack): 9618-12

QL2 Single Head (12 pack): 9272-18

INSTALLATION TIPS

- Never use saddle valve for connection
- Use 3/8" water line
- **Flush OCS cartridge by running two gallons through filter at full flow**

OPERATION TIPS

- Change cartridges:
 - on a regular 6 month preventative maintenance program
 - when the pressure gauge indicates a pressure less than 10 psi when the system is operating
 - or at least annually

Always flush the filter cartridges when changing

SPECIFICATIONS

Dimensions: 13-1/2"H x 4"W x 4"D

("H" dimension includes 2-1/2"
clearance for cartridge changing)

Minimum inlet connection: 3/8" NPT

Service flow rate: Minimum .5 gpm

Maximum 1.67 gpm

Working pressure: 10-125 psi, non-shock

Maximum temperature: 100°F (38°C)

No electrical connection required

Shipping weight: 3 lbs.

Operating weight: 8 lbs.

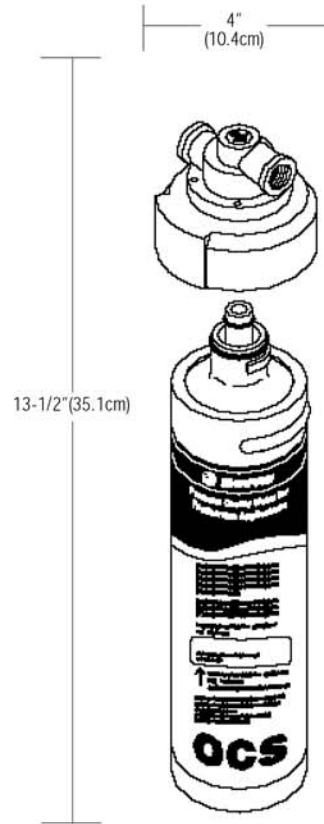

LIMITED WARRANTY OF PHYSICALQUALITY

If, within eighteen months after manufacture or twelve months after purchase (whichever occurs first), any part of Everpure, Inc. manufacture which is returned to its factory, shipping charges prepaid, is found to be defective in material or workmanship in the judgement of Everpure's engineers, Everpure, Inc. will repair or replace such part at no charge, f.o.b., Westmont factory. Everpure, Inc. however, shall not be liable for damages or delays caused by any defective material or workmanship, or by failure of any parts due to normal wear and tear. Everpure, Inc. will not be responsible for products which malfunction due to user neglect or unauthorized modification.

NOTE: Some states do not allow limitations on how long an implied warranty lasts, so the above limitation may not apply to you. Similarly, some states do not allow the exclusion or limitation of consequential or incidental damages, so the above limitation or exclusion may not apply to you. This warranty gives you specific legal rights and you may also have other rights which may vary from state to state.



System Tested and Certified by NSF International against ANSI/NSF Standard 42 and 53 for the reduction of:

Standard No. 42: Aesthetic Effects
Chemical Unit
Taste and Odor Reduction
Chlorine Reduction, Class I
Mechanical Filtration Unit
Particulate Reduction, Class I:
99.9+% reduction of particles
one-half micron and larger in size
Standard No. 53: Health Effects
Mechanical Filtration Unit
Turbidity Reduction
Cyst Reduction
Asbestos Reduction

Check for compliance with state and local laws and regulations. Do not use where the water is microbiologically unsafe, or with waters of unknown quality without adequate disinfection before or after the unit. May be used with disinfected water where filterable cysts may be present.

EVERPURE
WATER YOU CAN TRUST.